

PLAN OF SPEED HUMP
SCALE 1:100

NOTE
1. Traffic Signs:
1.1 Only galvanised bolts and nuts to be used on W and R series (no uni-struts)
1.2 All signs must be according to the Road Traffic Signs Manuals but use 900Φ STOP (60km/h zone) for 3-way and 4-way stops
1.3 All signs excluding R1 series must have rounded edges
2. ROADMARKINGS:
All new road markings in thermoplastic

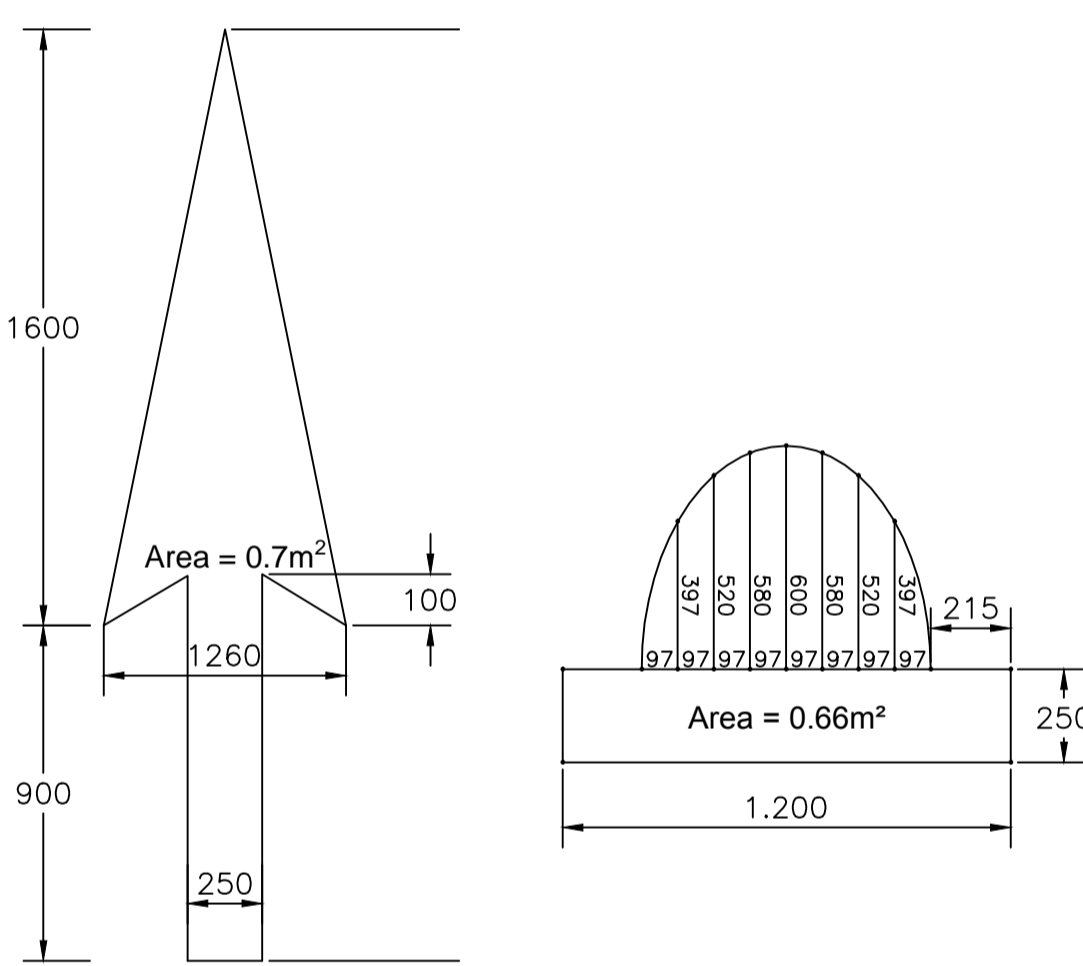

DETAIL OF SPEED HUMP ROAD MARKING
SCALE 1:20

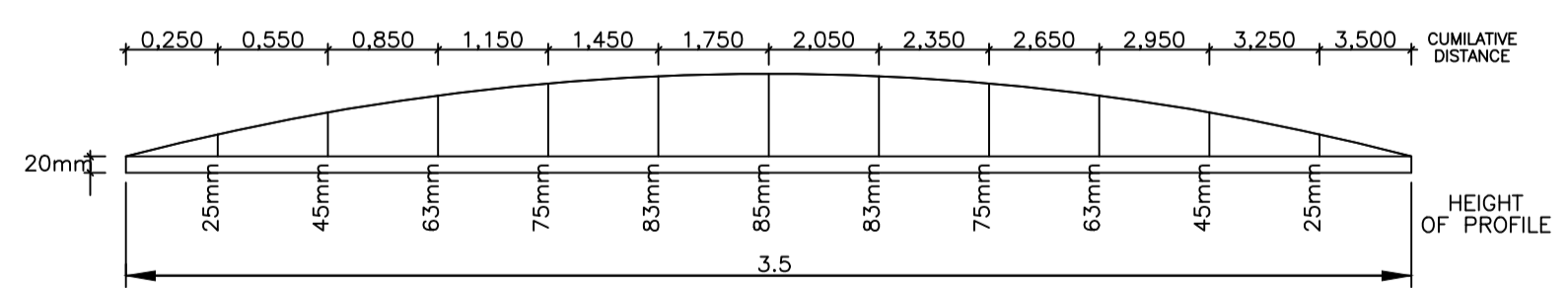

SIDE ELEVATION

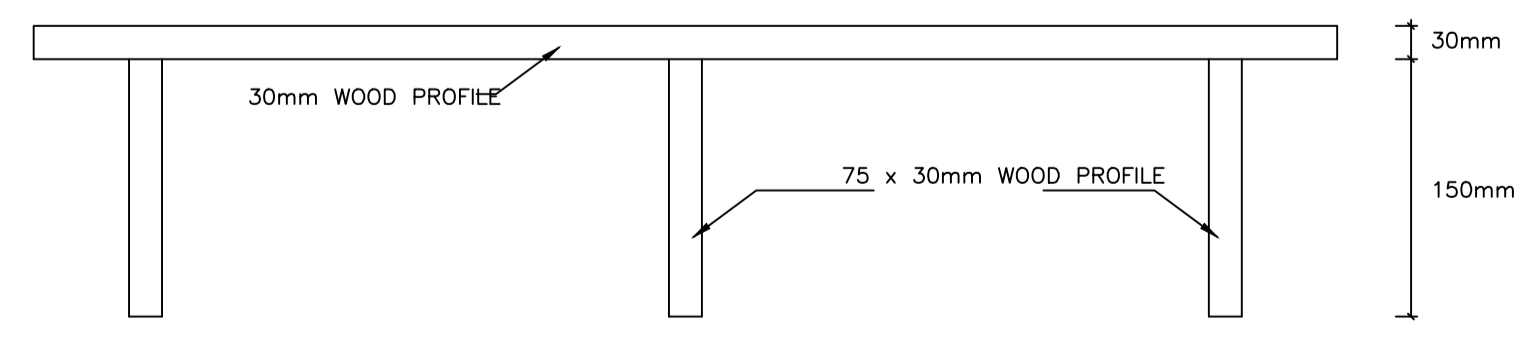

PLAN

TEMPLATE DETAIL FOR CONSTRUCTION OF SPEED HUMP
SCALE 1:20

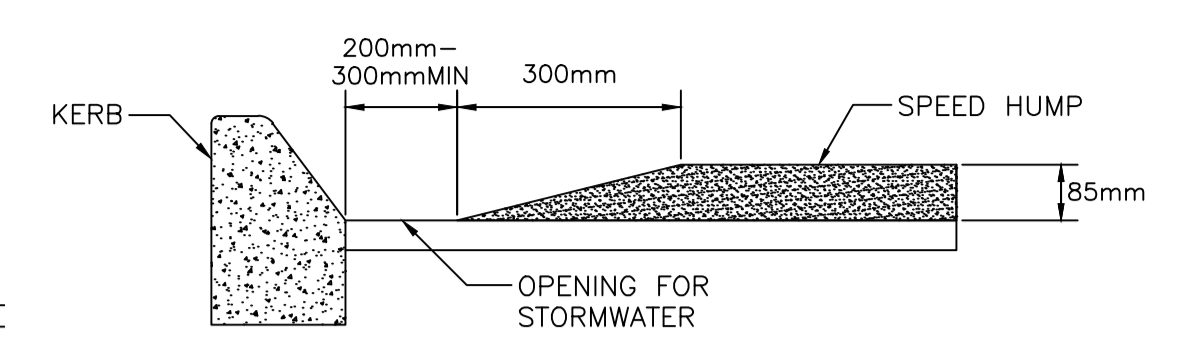

**SECTION A-A:
CONSTRUCTION DETAIL OF SPEED HUMP**
SCALE 1:100
50/60 Km/h

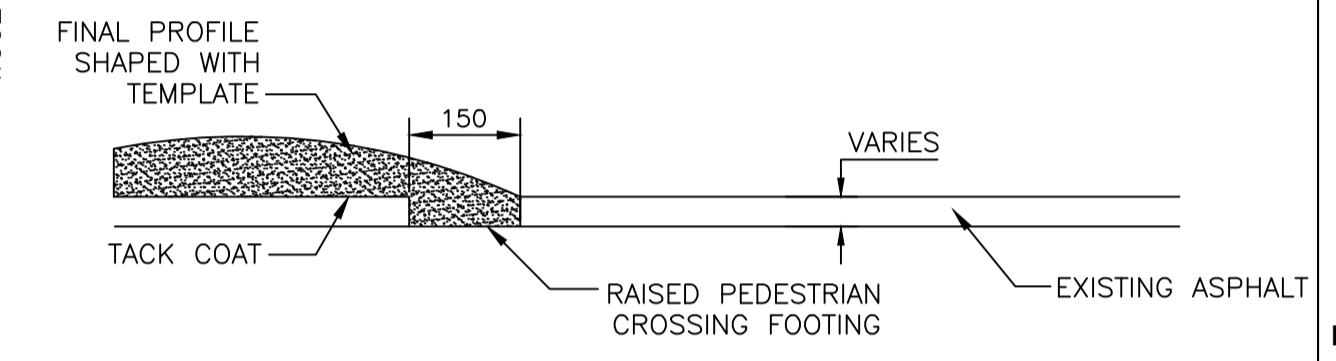

**SECTION B-B:
CONSTRUCTION DETAIL OF SPEED HUMP**
SCALE 1:100

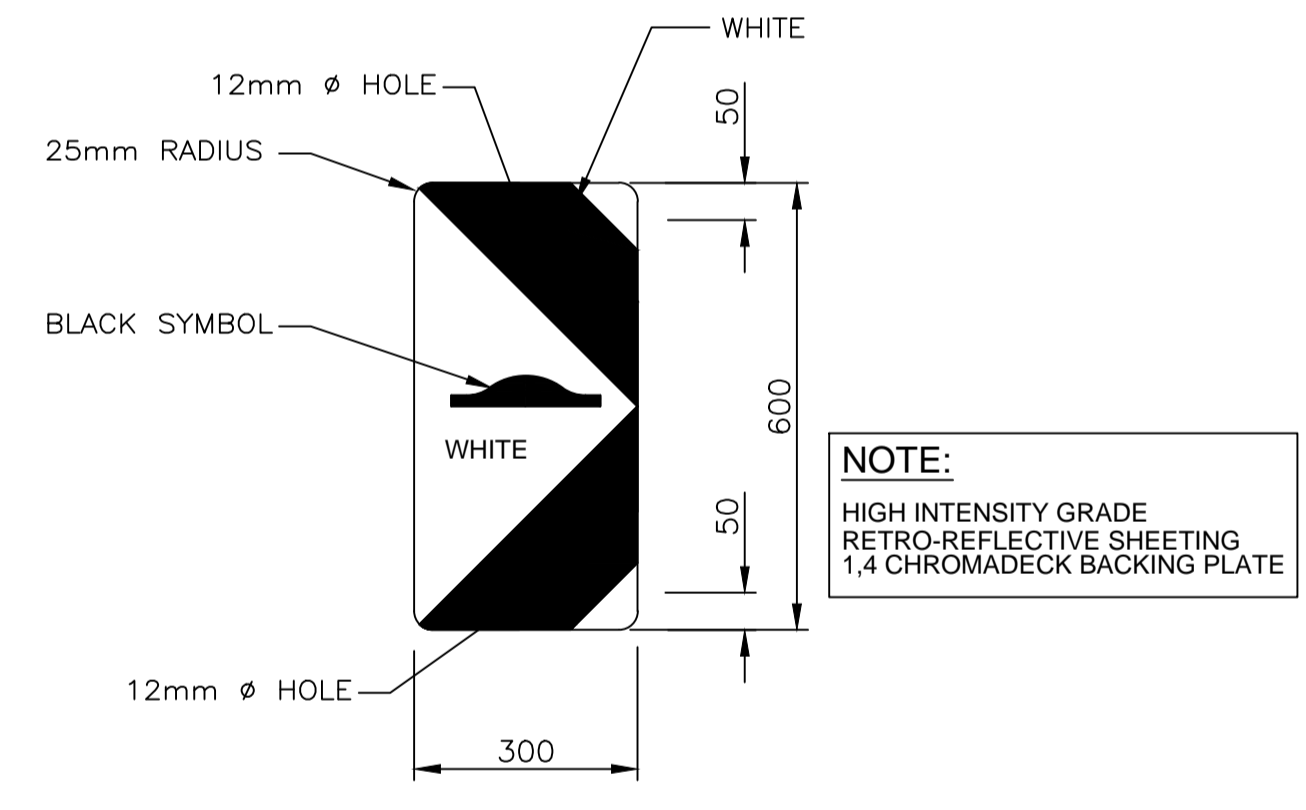

DANGER PLATE SPEEDHUMP (LEFT)
W416
SCALE 1:10

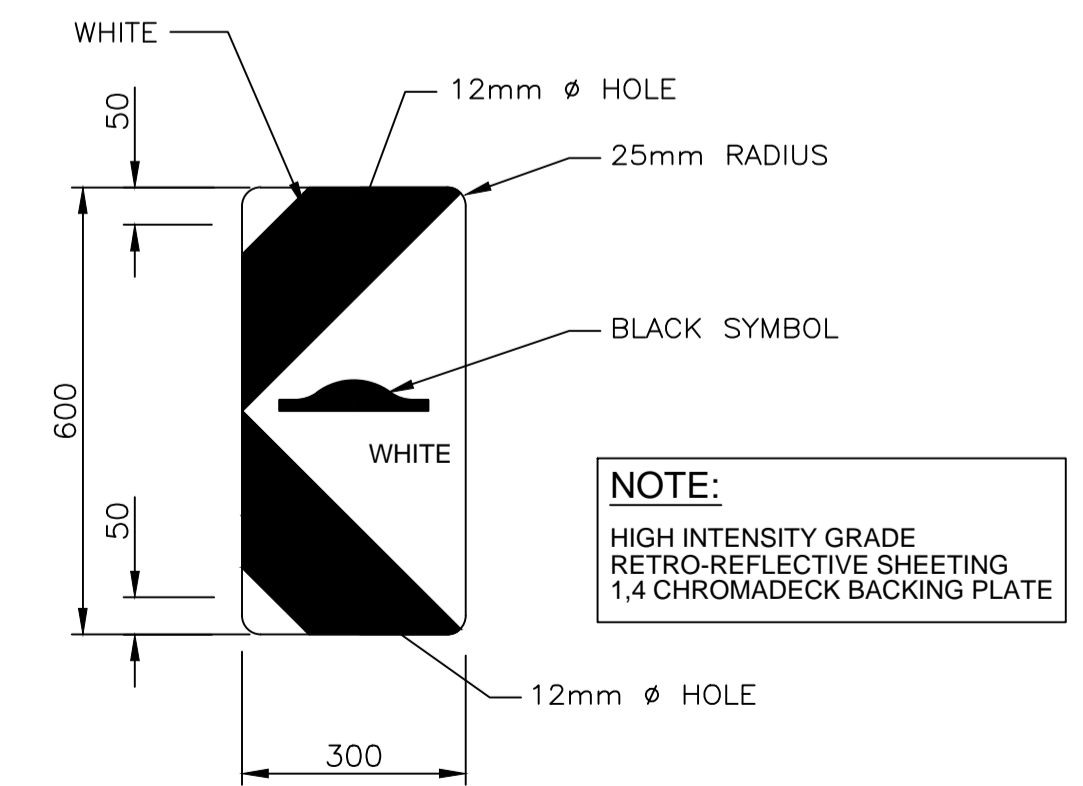

DANGER PLATE SPEEDHUMP (RIGHT)
W417
SCALE 1:10

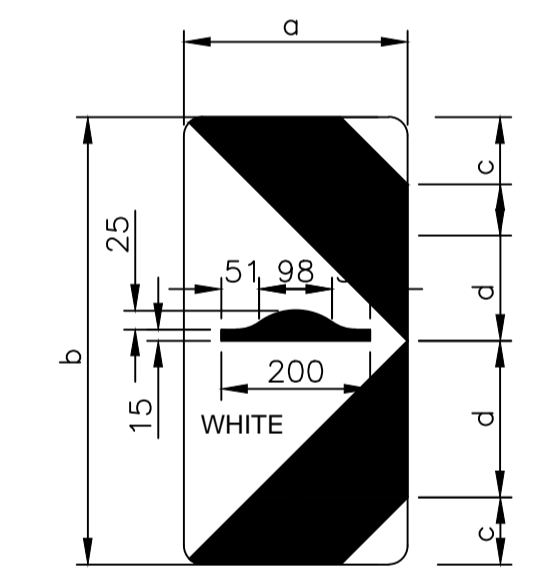

DIMENSIONS (mm)

a	b	c	d	R
300	600	90	210	25

DANGER PLATE SPEEDHUMP
W416
SCALE 1:10

NOTES AND SPECIFICATIONS

- CONSTRUCTION METHOD: SPEED HUMPS**
- Setting out of hump - few days before construction.
 - Saw cuts one to two days before construction.
- ON CONSTRUCTION DAY:**
- Remove 500 mm asphalt strips.
 - Start erecting road signs and paint warning road marking.
 - Place asphalt in strips and compact with two passes without vibrator.
 - Place templates - both sides of one lane at a time.
 - Place asphalt and rake till slightly higher than templates.
 - Shape asphalt with straight edge (channel section 6 m long).
 - Remove templates and compact without vibrator (three passes)
 - Measure profile and rectify if necessary.
 - Final compaction with three to four passes with vibrator.
 - Place road studs.
 - Paint speed hump the next day.
- Traffic Signs:
 - Only galvanised bolts and nuts to be used on W and R series (no uni-struts)
 - All signs must be according to the Road Traffic Signs Manuals but use 900Φ STOP (60km/h zone) for 3-way and 4-way stops
 - All signs excluding R1 series must have rounded edges
 - ROADMARKINGS:**
 - All longitudinal road markings in 1.2mm thick thermoplastic.
 - All small hand type markings namely STOP lines, Yield Lines, Pedestrian Crossing Lines, Block Pedestrian Crossings, Arrows and Symbols to be in thermoplastic (1.2mm thick) or two component cold plastic (MMA - Methyl Methacrylate) applied as a screed (1mm thick).

Colour	Paint application rate (mm)	Premix bead application rate (%)	Initial coefficient of retro-reflectance (m ² candela/s/lux/m ²)
WHITE	1.2mm thermo(1mm Cold)	35	250
YELLOW	1.2mm thermo(1mm Cold)	35	135

NOTE:
The Traffic Engineering and Operation section must always be consulted to assist with the setting out of speed humps.

AMENDMENTS

NRL	DATE	APPROVED	DESCRIPTION	PAR.

DESIGNED C.B. RAMEKANE	DRAWN S. AUDIE
DESIGN CHECKED BY P. A. ODENDAAL Pr.Eng.	INFRASTRUCTURE TECHNICAL INFORMATION MANAGEMENT D.J. CHALMERS

CITY OF TSHWANE
ROADS AND TRANSPORT DEPARTMENT

GROUP HEAD
Mr Letsoke P. (Pheko)
P.O. BOX 1409
PRETORIA
0001

ACTING DIVISIONAL HEAD
Mr Lebepe M.T. (Thabo)
P.O. BOX 1409
PRETORIA
0001

DRAWING APPROVED BY ACTING EXECUTIVE DIRECTOR
Mr Lebepe M.T. (Thabo)

TYPICAL STANDARD DETAILS

DESCRIPTION OF PROJECT
TRAFFIC CALMING MEASURES
TYPICAL SPEED HUMP AND ROADMARKINGS DETAIL

CONTRACT No.:	PROJECT No.:
DATE: 15 MARCH 2018	SCALE: AS SHOWN
DRAWING NO. STD016	SHEET NO. 1 OF 7

