

**PLAN OF RAISED PEDESTRIAN CROSSING (RPC)**

SCALE 1:100

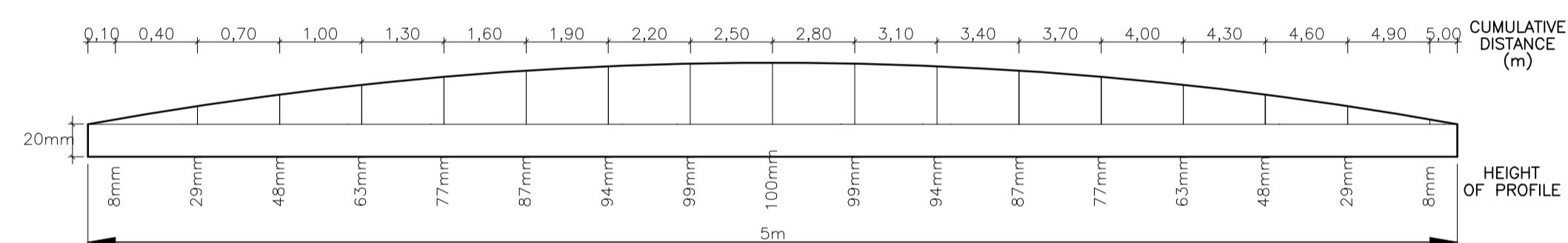

**SIDE ELEVATION**

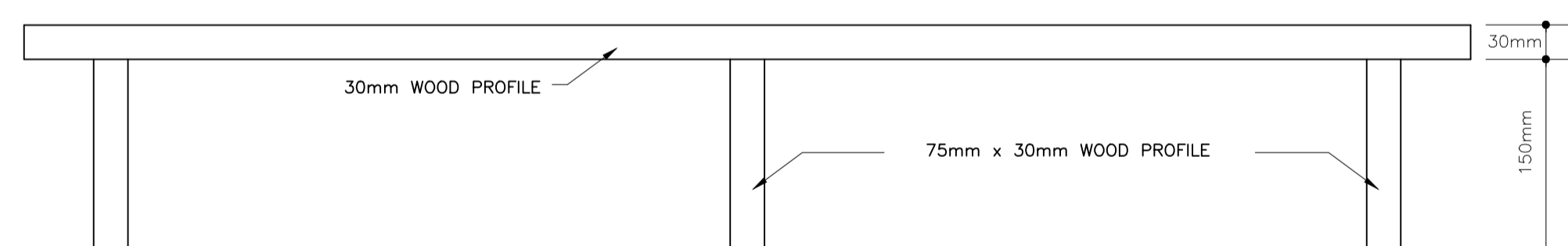

**PLAN**

**TEMPLATE DETAIL FOR CONSTRUCTION OF RPC**

SCALE 1: 20

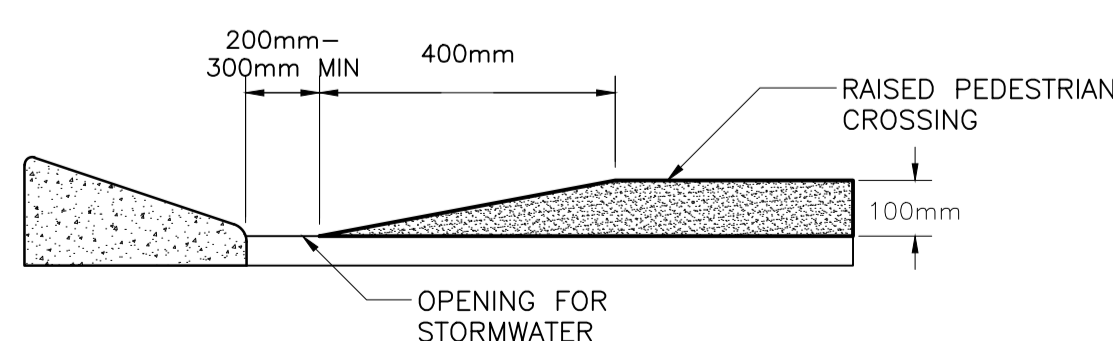

**SECTION A-A:  
CONSTRUCTION DETAIL OF RPC**

SCALE 1: 100

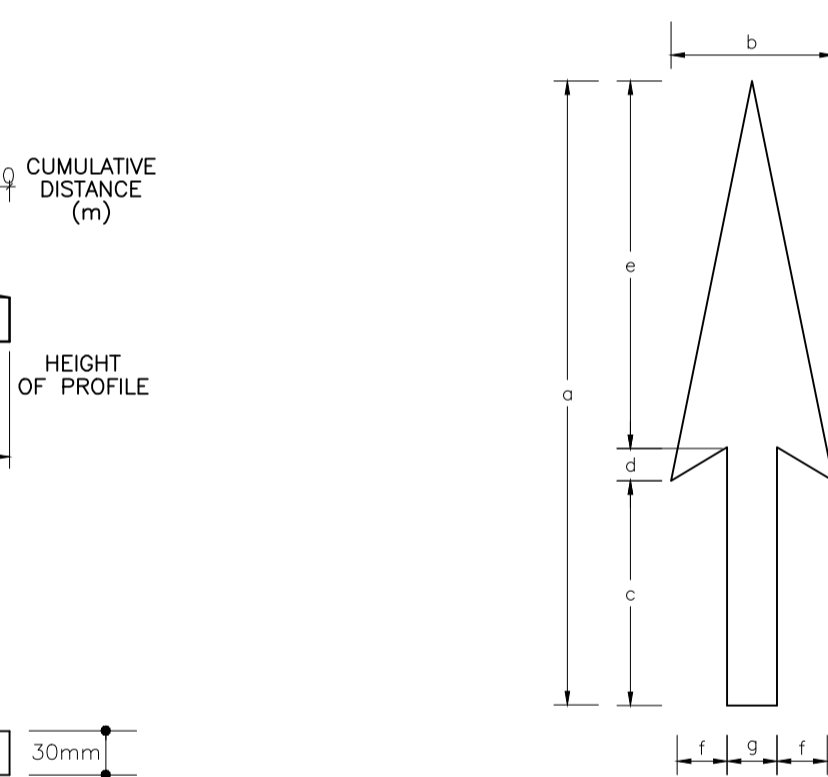

OPERATING SPEED Km/h	TYPICAL APPLICATIONS	a	a'	b	c	c'	d	e	f	g
30 - 40	CITY CENTRE	1250	2000	1250	450	400	50	750	500	250
50 - 60	URBAN	2500	4000	1250	900	800	100	1500	500	250

**DETAIL OF ROAD MARKING**

SCALE 1: 20

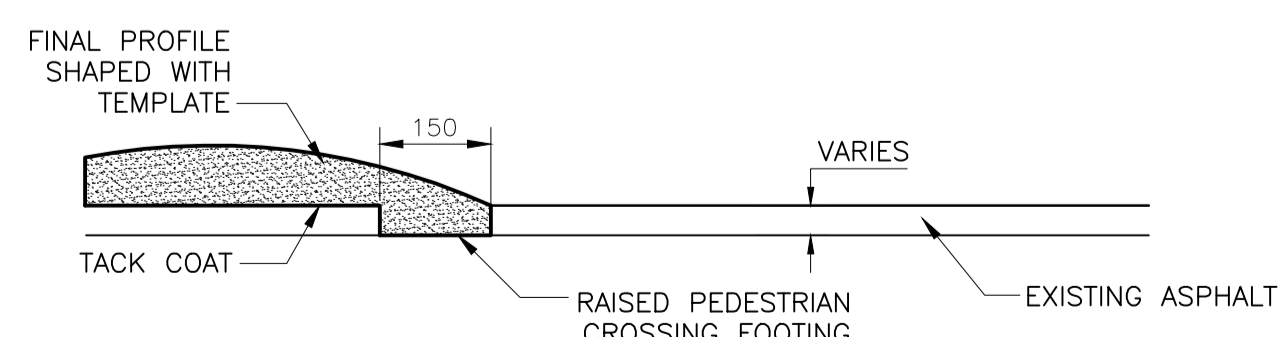

**SECTION B-B:  
CONSTRUCTION DETAIL OF RPC**

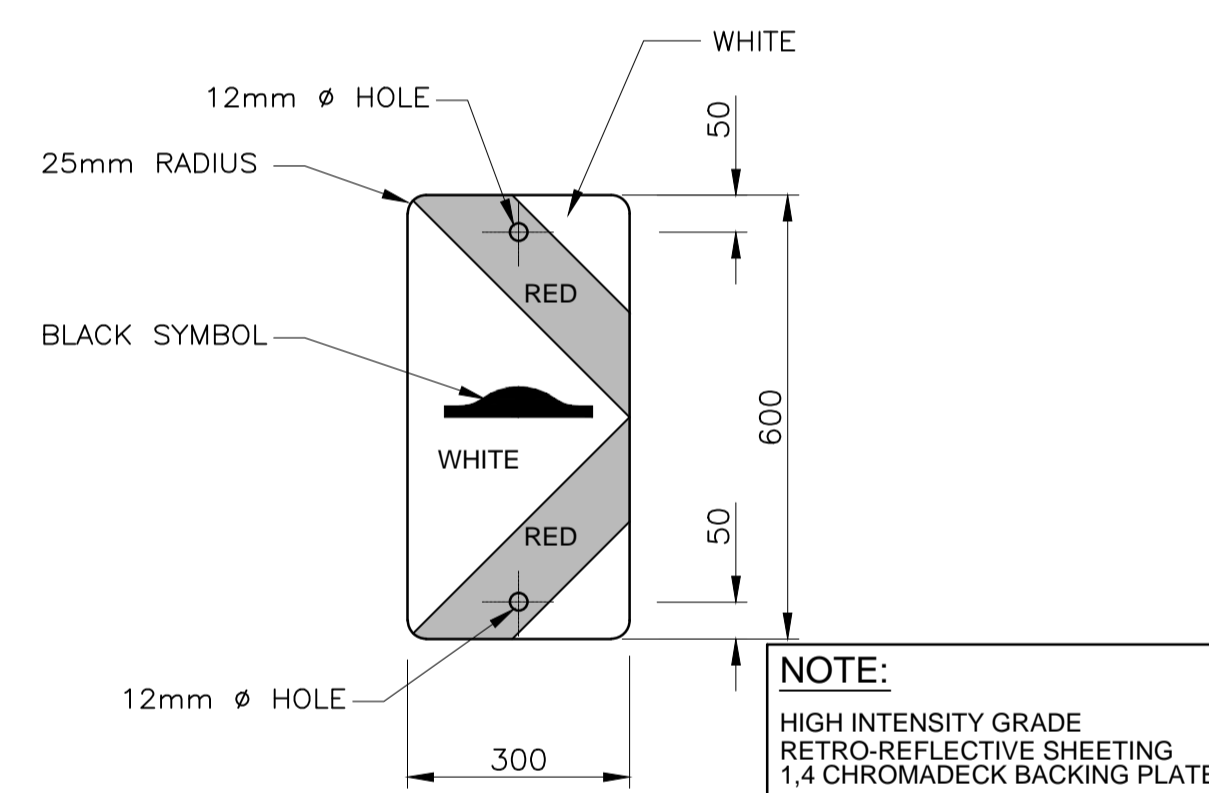

**DANGER PLATE (LEFT)**

W416

SCALE 1:10

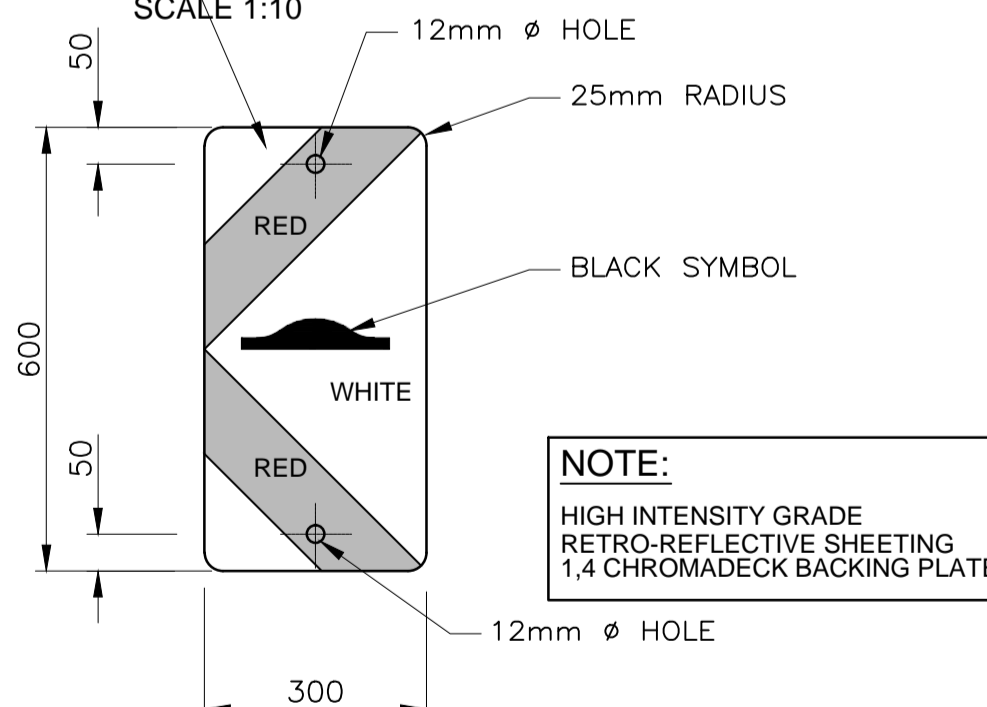

**DANGER PLATE (RIGHT)**

W417

SCALE 1:10

**NOTES AND SPECIFICATIONS**

**CONSTRUCTION METHOD: SPEED HUMPS**

- Setting out of hump - few days before construction.
- Saw cuts one to two days before construction.

**ON CONSTRUCTION DAY:**

- Remove 500 mm asphalt strips.
- Start erecting road signs and paint warning road marking.
- Place asphalt in strips and compact with two passes without vibrator.
- Place templates - both sides of one lane at a time.
- Place asphalt and rake till slightly higher than templates.
- Shape asphalt with straight edge (channel section 6 m long).
- Remove templates and compact without vibrator (three passes)
- Measure profile and rectify if necessary.
- Final compaction with three to four passes with vibrator.
- Place road studs.
- Paint speed hump the next day.

**Traffic Signs:**

- Only galvanised bolts and nuts to be used on W and R series (no uni-struts)
- All signs must be according to the Road Traffic Signs Manuals but use 900Φ STOP (60km/h zone) for 3-way and 4-way stops
- All signs excluding R1 series must have rounded edges

**ROADMARKINGS:**

- All longitudinal road markings in 1.2mm thick thermoplastic.
- All small hand type markings namely STOP lines, Yield Lines, Pedestrian Crossing Lines, Block Pedestrian Crossings, Arrows and Symbols to be in thermoplastic (1.2mm thick) or two component cold plastic (MMA - Methyl Methacrylate) applied as a screed (1mm thick).

Colour	Paint application (mm)	Premix bead application rate (%)	Initial coefficient of retro-reflectance (mcd/m <sup>2</sup> /lux/m <sup>2</sup> )
WHITE	1.2mm therm(1mm Cold)	35	250
YELLOW	1.2mm therm(1mm Cold)	35	135

**NOTE:**

The Traffic Engineering and Operation section must always be consulted to assist with the setting out of speed humps.

AMENDMENTS				
NR.	DATE	APPROVED	DESCRIPTION	PAR.

DESIGNED C.B. RAMEKANE	DRAWN S. AUDIE
CHECKED BY P. A. ODENDAAL Pr.Eng	INFRASTRUCTURE TECHNICAL INFORMATION MANAGEMENT D.J. CHALMERS

**CITY OF TSHWANE**  
ROADS AND TRANSPORT DEPARTMENT

GROUP HEAD  
Mr Letlankane P. (Pheko)

ACTING DIVISIONAL HEAD  
Mr Lebepe M.T. (Thabo)

P.O. BOX 1409  
PRETORIA 0001

P.O. BOX 1409  
PRETORIA 0001

DRAWING APPROVED BY ACTING EXECUTIVE DIRECTOR  
Mr Lebepe M.T. (Thabo)

**TYPICAL STANDARD DETAILS**

**TRAFFIC CALMING MEASURES**  
**TYPICAL RAISED PEDESTRIAN CROSSING**

CONTRACT No.:	PROJECT No.:
DATE: 15 MARCH 2018	SCALE: AS SHOWN
DRAWING NO. <b>STD016</b>	SHEET NO. 2 OF 7
ORIGINAL PAPER SIZE: A1	REVISION

